



FIELDQUIP

family business, Australian owned ...smarter gear ...smarter care



XHD/X-TREME SERIES SLASHER

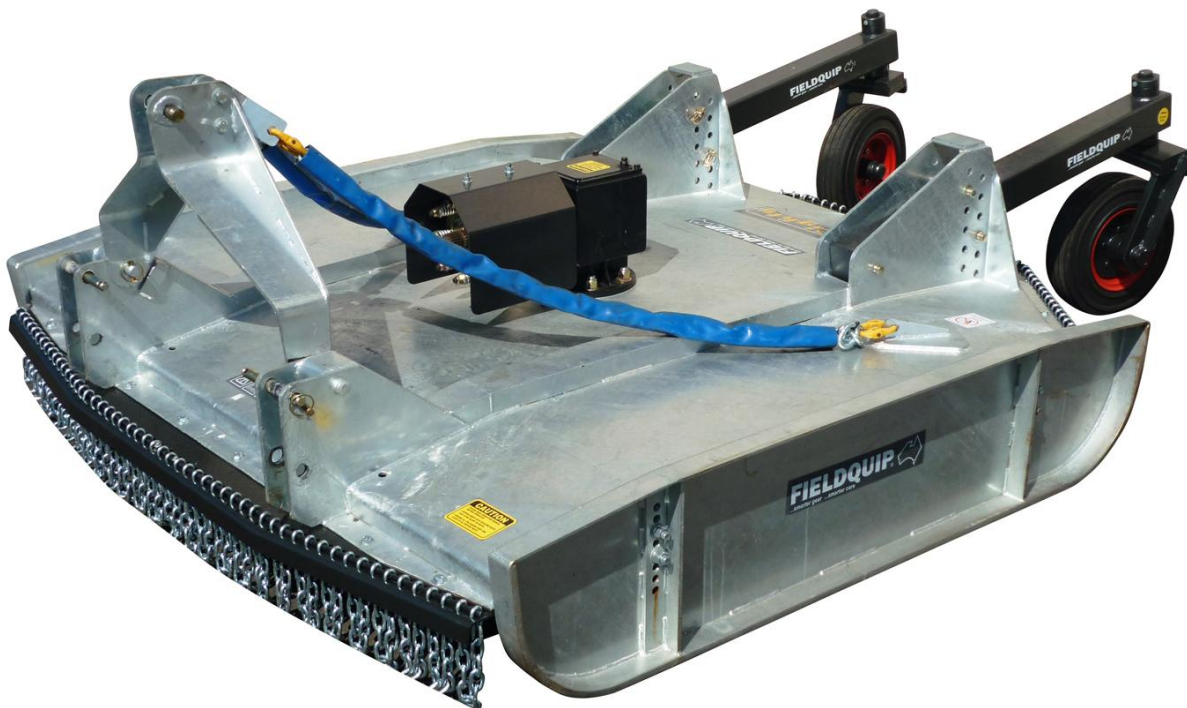

OWNER/OPERATOR MANUAL
SPARE PARTS LIST

Contents

DESCRIPTION	4
TO THE DEALER.....	4
TO THE OWNER.....	4
GENERAL INFORMATION.....	4
DECALS	6
SAFETY RULES & ACCIDENT PREVENTION.....	7
Operation	9
ASSEMBLY INSTRUCTIONS.....	9
Attaching to the Implement	10
The Power Take Off (PTO) Shaft	10
Daily Pre-Operation Checklist.....	11
Operating Technique	11
Cutting Height Adjustment.....	12
Removing Slasher from Tractor	13
OWNER SERVICE.....	13
Blocking Method.....	13
Lubrication Information.....	14
Cutter Bar and Blade Servicing.....	14
Setting the Clutch	14
The Clutch	15
Gearbox Service	16
Gearbox Maintenance.....	16
Gearbox.....	17
Gearbox Spare Parts.....	17
Spare Parts List for XHD Series Slasher	18
Spare Parts List for X-TREME Series Slasher	19
TROUBLESHOOTING	20
PRE-DELIVERY CHECKLIST	21
Dealer Delivery Information.....	21
WARRANTY	22
Warranty Procedure	22
Product Checklist – Delivery.....	23
DELIVERY, WARRANTY AND SAFETY ACKNOWLEDGEMENT	244

Fieldquip XHD/X-TREME Series Slasher

Operator Instructions and Parts List

Dear Customer,

We take this opportunity of welcoming you as the owner of a Fieldquip XHD/X-TREME Series Slasher. We want your XHD/X-TREME Series Slasher to be the most efficient and productive piece of equipment giving you years of satisfaction. This manual will help you to achieve this objective.

The safe operation and maintenance of your XHD/X-TREME Series Slasher is very important to prevent any personal injury and / or equipment damage. Read and fully understand the following instructions before operating or carrying out maintenance.

This instruction manual must be read in conjunction with the specific Tractor Operation Manual, Hazard Risk and Farm Machinery Safe Work Practices, prior to the equipment being placed in service.

Fieldquip warrants new products sold but it to be free from defects in material and workmanship for a period of twelve months for farmers or applications or six months for contractors, after delivery to the initial user. This warranty is for the replacement or repair of any part found to be defective during the warranty period. This warranty excludes any transport freight costs incurred by Fieldquip in giving effect to the warranty and specifically excludes all normal maintenance costs. This warranty also excludes loss of income incurred by the owner due to down time. Replacement parts provided under the terms of this warranty are covered for the remainder of the warranty period applicable to the product in which they are installed as if such parts were original components of that product.

It is the dealer's responsibility to deliver this unit to you fully assembled and to assist you in the instillation. Before use carefully check the entire machine for transit damage and report any problems immediately.

Fieldquip reserves the right to make changes or improvements in design and construction at any time, without incurring the obligation to make these changes on previously manufactured units.

Many Thanks,

The Manager

Fieldquip Pty Ltd
199 Bridge Street
Oakey QLD 4401
Ph: 07) 46911500

DESCRIPTION

The XHD/X-TREME Series Slasher by Fieldquip is a three point linkage tractor mounted implement designed for grass cutting. The XHD/X-TREME Series Slashers are available in three models which include the XHD70, XHD 80, XHD 90, X-TREME 70, X-TREME 80 and X-TREME 90. All models are covered in this manual.

Please ensure the unit you have purchased has the horse power rating to match that of your tractor.

Due to the very nature of this implement it is extremely important that you read and understand this owner's manual, before commencing operation.

TO THE DEALER

Assembly and proper installation of this product is the responsibility of the dealer. The dealer must complete all items on the Warranty Registration & Installation Form included in this manual before releasing the implement to the new owner. Both dealer and customer must sign the registration, which certifies that all Dealer Checklist items have been completed. The dealer must return a copy of the Warranty Registration & Installation Form to Fieldquip Australia. Reminders about Warranty Registration that have not been returned will be sent out to demonstrate that reasonable attempts have been made to ensure dealers complete risk assessment and pre-delivery obligations.

TO THE OWNER

Read this manual before operating your Fieldquip Australia implement. The information presented will prepare you to do a much better and safer job. Keep this manual handy as a reference. Ensure all operators read this manual carefully and become acquainted with all the adjustments and operating procedures before attempting to operate. Keep a record that the operator has read and understands the correct operating procedures as outlined in this manual. The implement you have purchased has been carefully engineered and manufactured to provide dependable and satisfactory use. Like all mechanical products, it will require routine cleaning, upkeep and maintenance. Lubricate the implement as specified. Observe all safety information in this manual and safety decals on the implement.

Your Safety is involved, be careful!

Safety is a primary concern in the design and manufacture of Fieldquip products. This implement like all mechanical products can cause serious injury if misused. Please ensure you read, understand and follow this manual for your own safety and that of others.

GENERAL INFORMATION

The purpose of this manual is to assist you in operating and maintaining your Fieldquip Rotary Slasher. Read it carefully. It provides information and instructions that will help you achieve years of dependable performance. These instructions have been compiled from extensive field experience and engineering data. Some information may be general in nature due to the unknown and varying operating conditions. However, through experience and these instructions, you should be able to develop procedures suitable to your particular situation. The illustrations and data used in this manual were current at the time of printing, but in an effort to bring you better products we are always implementing continuous improvements that may vary your implement slightly in detail. We reserve the right to redesign and change the machine as may be necessary without notice.

Throughout this manual, references are made to right and left direction. These are determined by standing behind the equipment facing the direction of forward travel. Blade rotation is anti-clockwise as viewed from the top of the Deck.

XHD Rotary Slasher Specifications

	XHD 70	XHD 80	XHD 90
Cutting Width	1750	1930	2150
Width (Overall)	1950	2150	2370
Length (Overall)	2550	2750	2950
Height (Overall)	1000	1000	1000
Weight Kgs (with PTO Shaft)	700	880	980
HP Requirements	50-130	70-130	75-130
Cutter Ft/Min	18,900	17,500	18,730
Number of Blades (Standard)	2	2	2
PTO Speed	540	540	540
3 Point Linkage Cat	I & II	I & II	I & II
Clearance Blade to Deck	320	320	320
Min Cutting Heights mm	25	25	25

Specifications are subject to alteration without notice.

	X-TREME 70	X-TREME 80	X-TREME 90
Cutting Width	1750	1930	2150
Width (Overall)	1950	2150	2370
Length (Overall)	2550	2750	2950
Height (Overall)	1000	1000	1000
Weight Kgs (with PTO Shaft)	790	910	1010
HP Requirements	50-200	70-200	85-200
Cutter Ft/Min	18,300	18,000	19,880
Number of Blades (Standard)	2	2	2
PTO Speed	1000	1000	1000
3 Point Linkage Cat	I & II	I & II	I & II
Clearance Blade to Deck	320	320	320
Min Cutting Heights mm	25	25	25

Specifications are subject to alteration without notice.

DECALS - All Models

Attention Be Careful! Your Safety is Involved

Replace Immediately if Damaged or Worn

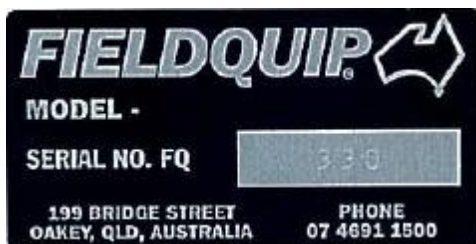
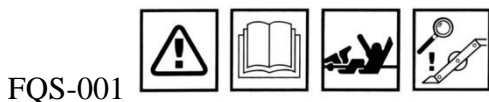

Each machine comes with its own serial number plate which will show the model and serial number starting with FQ. This number identifies the implement for spare parts enquires and to complete your warranty form.



SAFETY RULES & ACCIDENT PREVENTION

ATTENTION BE CAREFUL YOUR SAFETY IS INVOLVED

Safety is a primary concern in the design and manufacturing of our products. Unfortunately, our efforts to provide safe equipment can be wiped out by a single careless act of an operator. In addition to the design and configuration of equipment, hazard control and accident prevention are dependent upon the awareness, concern, prudence and proper training of personnel involved in the operation, transport, maintenance and storage of equipment.

Under no circumstances whatsoever should the tractor/implement combination, be operated whilst carrying a passenger either on or in the tractor or on the implement.

Remember it is the owner's responsibility to ensure all operators are fully informed and trained.

Safety instructions are important! Read all attachments and unit manuals; follow all safety rules and safety decal information. Failure to follow instructions can result in serious injury or death.

- Do not allow anyone under the age of 18 or untrained persons to operate equipment.
- Do not operate the implement or tractor whilst under the influence of drugs or alcohol.
- Know your controls and how to stop quickly in an emergency.
- Ensure your tractor has a fire extinguisher and you know how to operate the extinguisher in the event of an emergency.
- Tractors MUST be fitted with Roll-Over Protection Structure (ROPS) or (ROPS Cab). It is also advised that your tractor be fitted with a seatbelt, where fitted it must be worn at all times. Falling from your tractor can result in death from being run over or crushed. If your tractor is fitted with a folding ROPS keep it in the "locked up" position at all times.
- Always wear relatively tight fitted clothing, heavy duty, rough-soled boots and protective equipment for eyes, hair, hands, hearing and head.
- Operate only in daylight or good artificial light.
- Keep hands, feet, hair, and clothing away from moving parts while engine is running.
- Keep all people and animals away from the implement during start up, operating and when stopping.
- Never discharge directly toward people, animals or property.
- For transportation on public roads the operator must ensure that the tractor and implement complies with current State and Federal laws and must strictly adhere to all road traffic regulations in force in his/her particular state.
- Never operate along roads, pathways or populated areas without approved chains or shielding fitted to the implement. If the shielding is missing or is damaged, operation must cease until rectified.
- When working in populated areas always place signs in the area to alert people or vehicles that may pass. Operation must be stopped when anyone comes within 100 metres.
- Ensure all safety decals are installed. Replace if damaged.
- Ensure shields and guards are properly installed and in good working condition. Replace if damaged.
- Remove any debris that has accumulated on the implement, tractor or engine to avoid fire hazard.
- Keep hands and body away from pressurized lines. Use paper or cardboard, not hands or other body parts, to check for leaks. Wear safety goggles. Hydraulic fluid (oil) under pressure can easily penetrate the skin and will cause serious injury or death.
- Make sure that all operating and service personnel know that if hydraulic fluid (oil) penetrates the skin, it must be surgically removed as soon as possible by a doctor familiar with this form of injury. Otherwise, gangrene, serious injury or death will result.

Contact a Physician immediately if fluid enters skin or eyes. Do not delay.

- Never place any part of the body underneath the implement or between moveable parts even when engine has been turned off. Hydraulic systems can “creep” (slowly lower). They may fail or movement of the control levers can cause the implement to drop or rotate unexpectedly causing severe injury or death.
- Follow Operators Manual instructions for working on your implement or have servicing carried out by a qualified dealer.
- No operator, however experienced in farm machinery operation, should attempt to use any piece of machinery until they have been competently trained in its proper use.
- Operators must be instructed in and be capable of the safe operation of the equipment and all controls. Do not allow anyone to operate this equipment without proper instruction.
- If you do not understand any part of this manual and need assistance the Department of Agriculture, Occupational Health & Safety Offices, any Agricultural School or college and your local dealer should be able to direct you on where you can receive appropriate training.
- Inspect operating area, remove where possible any stones or foreign objects that may cause injury or damage. It is very important to always watch for foreign objects in the area you are operating and avoid any that could cause injury or damage.
- During routine checks and or repairs ensure that no one can switch on the tractor or implement accidentally. Keep the key to the tractor in your pocket.
- Make sure the tractor is turned off with the key removed, hand brake applied and wheel chocked whilst performing any servicing or routine checks.
- Check that all hardware is tight and properly installed.
- Firmly tighten all nuts/bolts/screws/shackles before operating. If worn or damaged, replace immediately.
- Ensure implement is properly attached, adjusted and in a good condition so that it can be operated safely.
- Make sure all spring activated locking pins or collars on the Power Take-Off (PTO) move freely, are well greased and are firmly seated in the tractor PTO splined angular groove.
- Before commencing operation, check all equipment driveline guards for damage and make sure they rotate freely. Replace any damaged guard or guards that do not rotate freely on drivelines.
- Inspect chains, shackles, deflectors and any wear parts for damage. Replace if damaged.
- Do not operate implement unless side skids are in good condition. Replace if damaged.
- Before commencing any adjustment, maintenance, or cleaning always park tractor and implement on good level ground, disengage the PTO, switch off the tractor engine, remove key and apply hand brake.
- Before dismounting tractor lower the 3-point linkage and any other raised components (i.e. loader bucket) to the ground. Operate valve levers to release any hydraulic pressure, and unfasten seat belt. Once dismounted chock wheels and ensure implements are safely supported. Ensure all moving parts have come to a complete stop. Disconnect driveline from the tractor PTO before performing any service work.
- For your own and others safety and to avoid forfeiting your warranty, use only genuine spare parts. Your dealer can supply you with genuine replacement parts.
- Do not modify/alter or permit anyone else to modify/alter the implement or any of its components.
- Block implements securely for storage.
- Keep children and by standers away from storage area.
- Fieldquip Australia accepts no responsibility or liability for any losses, injuries or damage that may result from failing to observe these safety rules and the safety decals on the implement.
- Do not handle blades with bare hands. Careless or improper handling may result in serious injury.
- Frequently check blades. They should be sharp, free of nicks and cracks and securely fastened. Replace if necessary. Always use genuine Fieldquip Blades. Your dealer can supply you with genuine replacement blades.
- Always replace blade bolts and bushes whenever you replace the blades.

OPERATION

"The best safety device is an informed careful operator."

The operator is responsible for the safe operation of this implement. The operator must be properly trained and over the age of 18. Operators should be familiar with the implement and tractor and all safety practices before starting operation. Read safety rules and safety decal information before starting operations.

- Always operate equipment from the seat of the tractor with the seat belt securely fastened. Place transmission in neutral, engage brake and ensure all other controls are disengaged before starting tractor engine.
- A minimum 20% of tractor and equipment weight must be on the tractor's front wheels with implement in the transport position. Without this weight, tractor could tip over causing personal injury or death. The weight may be attained with a loader, front wheel weights, and ballast in the tyres or front tractor weights. When attaining the minimum 20% weight on the front wheels, you must not exceed the ROPS max ballasted mass certificate. Weigh the tractor and implement. Do not estimate.
- Never leave a tractor and implement running unattended.
- Do not carry persons or objects on the implement or tractor during work or while in transit.
- Look down and to the rear and make sure area is clear and safe before traveling in reverse.
- Use extreme care when working close to fences, ditches, hillsides or other obstacles.
- Do not operate or transport on steep slopes.
- Do not stop, start or change directions suddenly when traveling on slopes.
- Do not stop, start or change directions suddenly on slopes', working up and down is preferred.
- Use extreme care and reduce ground speed on slopes and rough terrain.
- Watch for hidden hazards on the terrain during operation and avoid any hazards or object that could cause injury or damage.
- Stop implement, then tractor, immediately upon striking an obstruction. Turn off engine, remove key, inspect and repair any damage before resuming operations. Always block implement when inspecting.
- Do not operate tractor PTO during transport or when implement is raised more than 150mm above the ground. Disconnect the PTO when raising the slasher above working height.
- Disconnect driveline from the tractor PTO before performing any service work.
- Operate tractor PTO at rpm speed as stated in "Specifications" section. Always ensure the correct setting on your tractor before start up.

ASSEMBLY INSTRUCTIONS

- Depending on the location of the dealer, the implement may be shipped partly assembled or in parts. In any case, the assembly of this implement is the responsibility of the Fieldquip dealer. It should be delivered to the new owner completely assembled, lubricated and adjusted for normal cutting conditions. Final assembly should result in the Rotary Slasher looking like the photos pictured earlier in this manual.
- Make sure all spring activated locking pins or collars on the Power Take Off (PTO) Shaft move freely, are well greased and are firmly seated in the tractor PTO splined angular groove.
- Firmly tighten all nuts, bolts, screws and shackles before operating.
- Do not operate the implement unless it has chains or rubber shielding in place.

ATTACHING TO THE IMPLEMENT

- Always connect the tractor to the implement on a level surface and never stand in between the tractor and the implement.
- Always adjust the tractor lower linkage arms anti-sway devices to prevent implement from swinging from side to side during transport and operation. Failure to do so may result in serious injury or damage. Damage like bent and twisted implement towers are consumable items and are NOT covered by warranty.
- Line the tractor up so that the double clevis mounting point on the implement can be connected to the lower link arms of the tractor and secured with lynch pins. Attach tractor top link to implement top double clevis with top hitch pin and secure with lynch pin. Always ensure that the tractor connection (lower arms or top link) are not outside the double clevis mounting point.

THE POWER TAKE OFF SHAFT (PTO)

- PTO shafts come in standard lengths so that they can be adapted to all tractors. This means that you may have to shorten the PTO Shaft to suit your tractor. Hold the male and female sections parallel to each other and check for a minimum 15cm overlap. If there is less than the minimum overlap, do not use that shaft. Contact your dealer and you may need to purchase a special shaft for your situation. If it is too long, equal lengths must be cut off both the male and female shafts. Trim the external plastic guards first and then the shaft itself. Always measure twice then cut once, de-burr ends and clean away all chips and rough edges with a file, then re-grease both shafts and reassemble PTO Shaft.
- Always wear relatively tight fitted clothing to avoid entanglement in moving parts. Wear heavy duty, rough-soled boots and protective equipment for eyes, hair, hands, hearing and head when carrying out any servicing or operational tasks.
- Always check the plastic guarding on PTO shaft and the plastic clutch cover on the gearbox. If worn or damaged then replace immediately.
- Make sure all spring activated locking pins or collars on the Power Take Off (PTO) Shaft move freely, are well greased and are firmly seated in the tractor PTO splined angular groove.
- To secure the PTO to the tractor you will see that there is a spring activated locking pin on both ends of the PTO Shaft. Push this pin in and slide the PTO onto either the tractor output shaft or the implement input shaft. Continue to slide the PTO onto the shaft until it becomes firmly seated in the angular groove. Always ensure that both ends are locked into the angular groove before engaging the PTO Shaft.
- Depending on the model of tractor that is being used with the implement it may be possible to raise the implement to a point where the PTO fouls on the frame of the implement. This can bend your PTO shaft and may cause serious injury or damage. When commencing operations slowly raise the implement via the linkage. If the PTO shaft looks like it will touch before the linkage reaches the maximum lift, then set a "STOP" on the tractors hydraulic lower linkage arms so that the operator cannot go past this point during operation, do not commit it to memory.
- Operate tractor PTO at rpm speed as stated in "Specifications" section. Always ensure the correct setting on your tractor before start up.

DAILY PRE-OPERATION CHECKLIST

(Owners Responsibility)

- Review and follow safety rules outlined in this manual.
- Check the implement is properly and securely attached to the tractor.
- Make sure PTO spring activated locking pin is well greased, slides freely and is firmly seated in tractor PTO splined angular groove.
- Set tractor PTO at 540 rpm (Some Multi-Heads may have been designed for 1000rpm).
- Lubricate all grease fitting locations. Make sure PTO joints and shaft are well lubricated.
- Remove small oil level plug on side of gearbox and assure oil leaks out. Top up if no oil is present.
- Check all hardware (i.e. bolts, nuts, shackles, chains, etc) are properly installed, secured and in good condition.
- Check blades are sharp and secure and cutting edge is positioned to lead when rotating anti-clockwise.
- Check that all shields and guards are properly installed and in good condition.
- Check cutting height, front to rear attitude and top link adjustment.
- Set slip clutch as outlined in "Owner Service" section of this manual.
- Ensure tractor PTO and transmissions are in neutral before starting engine.
- Inspect area that you will be operating in and remove any object that may cause injury or damage.
- Vibration tends to loosen bolts during operation. All hardware should be checked regularly. It is good practice to check implement before each operation to ensure all hardware is secure.

OPERATING TECHNIQUE

- Power for operating a Rotary Cutter is supplied by tractor PTO. Know how to stop tractor and slasher quickly in case of emergency. Always make sure the correct PTO setting is selected before starting the tractor. Never transport the implement with the PTO engaged.
- Set up your implement for the type of finish you are looking for as specified in the "Cutting Height Adjustment" of this manual, then return to the tractor seat, fasten seat belt, make sure tractor is in neutral and all other controls are disengaged before starting tractor engine.
- With the Rotary Cutter lowered, start tractor engine and engage PTO while the tractor engine has low rpm to minimize stress on the driveline and gearbox. With PTO engaged, raise engine rpm until PTO speed is 540 rpm (or 1000rpm on some Multi Head Rotary Cutters). Maintain throughout cutting operation.
- Always operate tractor PTO at the rpm as specified in the "Specifications." This is necessary to maintain proper blade speed and produce a clean cut. A slower PTO speed will result in blades and bushes moving around due to the low centrifugal, which will lead to excessive wear.
- Gearbox protection is provided by a slip clutch with replaceable discs. The slip clutch is designed to slip when excessive torsion loads are encountered. Always make sure the clutch is set and working correctly before operating.
- Move into material slowly with Rotary Cutter. Adjust tractor ground speed to provide a clean cut without straining the tractor engine. If tractor engine is straining, reduce amount of material being cut by taking a narrower pass. Ground speed will depend upon the terrain, the height, type and density of the material being cut. Normal ground speed will range from four to eight kph (two to five mph). Tall dense material should be cut at low speed; thin medium-height material can be cut at a faster ground speed. Use a slow ground speed for finer cutting.
- Under certain conditions, tractor tyres may roll some grass down and prevent it from being cut at the same height as the surrounding area. When this occurs reduce ground speed, but maintain the specified rpm at the PTO. The slower ground speed will at least give the grass time to partially rebound and get cut.
- Under some conditions, grass will not rebound enough to be cut evenly. In general, lowering cutting heights gives a more even cut with fewer tendencies to leave tyre tracks. However, it is better to cut grass frequently rather than too short.
- Short grass deteriorates rapidly in hot weather and invites weed growth during growing seasons.

- Inspect operating areas and remove any foreign objects that could be thrown. It is very important to always watch for foreign objects when you are operating and avoid them as they can cause injury or damage.
- Extremely tall material should be cut twice. Set Rotary Cutter at a higher cutting height for the first pass. Then for the second pass cut at desired height, 90° to the first pass. Remember, sharp blades produce a cleaner cut and require less horsepower.
- Analyse the area to be cut to determine the best procedure. Plan your operating pattern to travel straight forward whenever possible. Mow clockwise around fields when possible to minimize streaking on corners. Consider height and type of grass and terrain type (e.g. hilly, level, rough). Always allow for the effect that the weight of an implement has on the tractor particularly on hilly or unstable terrain. It is recommended that in hilly situations you work straight up and down not across the slope.
- Do not operate on steep slopes, if in doubt set rear axles wider or only operate on moderate slopes.
- Do not stop, start or change directions suddenly on slopes, working up and down is recommended.
- Use extreme care and reduce ground speed on slopes and rough terrain.
- Watch for hidden hazards on the terrain during operation.
- Pass diagonally through sharp dips and avoid sharp drops to prevent “hanging up” tractor and slasher. Practice will improve your skills in maneuvering on rough terrain.

CUTTING HEIGHT ADJUSTMENT

- Avoid low cutting heights. Striking the ground with blades produces one of the most damaging shock loads a slasher can encounter. Allowing blades to repeatedly make contact with the ground will cause damage to the Slasher and drivelines (i.e. PTO Shaft).
- Keep all persons away from operators control area while performing adjustments, service or maintenance.
- During routine checks and/or repairs ensure that no one can switch on the tractor or implement accidentally. Keep the key to the tractor in your pocket.
- The Rotary Cutter should be operated at the highest position that will give the desired cutting result. This will help prevent the blades striking the ground, reducing blade wear and undue strain on the implement. For best results under heavier cutting conditions, always tilt the implement so that the front is 25-50mm lower. This tilt decreases the horsepower requirements and increases potential ground speed. When fine cutting is desired, adjust the implement so the deck is level or slightly lower in the rear. This will keep the foliage under the cutter until thoroughly shredded. Operating in this manner will require more horsepower and a slower ground speed to get the desired result.
- Never place any part of the body underneath the implement or between moveable parts even when engine has been turned off. Hydraulic systems can “creep” (i.e. slowly lower). They may fail or movement of the control levers can cause the implement to drop or rotate unexpectedly causing severe injury or death.
- Follow Operator’s Manual instructions when working on your implement or have servicing carried out by a qualified dealer.
- Before commencing any adjustment, maintenance, or cleaning. Always disengage the Power Take Off (PTO) Shaft, switch off the tractor engine, remove key and wait until all moving parts have come to a complete stop, then ensure the machine is on level ground or on a robust secure support.
- The cutting height may be adjusted from 25mm to 100mm by selecting the appropriate holes in the skids. Always ensure that every setting is the same. Should a wheel kit be fitted then the height is adjustable from 25mm to 300mm.
- In both situations remove the bolt, adjust the implement to the desired height, and replace bolt and spring washer then secure nut tightly.

REMOVING SLASHER FROM THE TRACTOR

- It is more than likely that you will have the implement in the transport position and therefore the PTO should already be disengaged. Never transport the implement with the PTO engaged. Lower implement and all attachments (i.e. loader buckets) all the way to the ground and wait for all moving parts to come to a complete stop. Turn of tractor ignition and remove key. Firmly apply park break, remove seatbelt and dismount the tractor. Remove check chains (if installed). Disconnect the PTO Shaft from the tractor and implement by de-pressing spring-activated locking pin.
- Collapse PTO Shaft inside itself as far as possible and store in a dry area undercover. Block implement securely for storage with robust secure supports then remove top and lower linkage pins. Make sure that the tractor's lower linkage arms are free and return to tractor seat. Start tractor as specified in the tractors operating manual, select a low gear and slowly drive away from the implement making sure that it does not fall.

OWNER SERVICE

The information in this section is written for operators who possess basic mechanical skills. Should you need help, your dealer has trained service technicians available. For your protection, read and follow safety information in this manual.

- Disengaged tractor PTO and wait for all moving parts to come to a complete stop. Lower implement to the ground or block with secure robust support. Turn tractor engine off, remove key and disconnect PTO Shaft from the tractor before performing any service or maintenance.
- Keep all persons away from operator control area while performing adjustments, service or maintenance.
- During routine checks and/or repairs ensure that no one can switch on the tractor or Implement accidentally. Keep the key to the tractor in your pocket.
- Always wear relatively tight fitted clothing to avoid entanglement in moving parts. Wear heavy duty, rough-soled boots and protective equipment for eyes, hair, hands, hearing and head.

BLOCKING METHOD

To minimize the potential hazards of working underneath the implement, these procedures must be followed.

- Never go underneath implements that are lowered to the ground or raised, unless it is properly blocked and secure. Never place any part of the body underneath the implement or between moveable parts even when engine has been turned off. Hydraulic systems can “creep” (i.e. slowly lower). They may fail or movement of the control levers can cause the implement to drop or rotate unexpectedly causing severe injury or death.
- Follow Operator's Manual instructions for working on your implement, correct blocking procedures or have servicing carried out by a qualified dealer.
- During routine checks and/or repairs ensure that no one can switch on the tractor or Implement accidentally. Keep the key to the tractor in your pocket.
- Jack stands with a load rating of 1000lbs or more are the only approved blocking devices for this implement. A minimum of four (4) jack stands, located under the implement must be installed before working underneath the implement. Do not position jack stands under wheels, axles or wheel supports as components can rotate and cause implement to fall.
- When blocking, you must consider the overall stability of the implement. Just placing jack stands under the unit will not ensure your safety. The working surface must be level and solid to support the weight of the jack stands. Ensure jack stands are stable both top and bottom, and implement is approximately level. With full implement weight lowered onto jack stands, test blocking stability before beginning working underneath implement.
- Implement should be properly and securely attached to the tractor (see operating section), the brakes firmly set, key removed and both front and rear tractor wheels securely blocked.

LUBRICATION INFORMATION

- Do not let excess grease collect on or around parts, particularly when operating in sandy conditions.
- When greasing implement, be sure to clean fittings thoroughly before attaching grease gun. Fieldquip Australia Pty Ltd recommends Lithium Grease with a #2 consistency for all locations, unless otherwise noted.
- Fieldquip Australia Pty Ltd, in conjunction with the gearbox manufacturer recommends high quality gear oil with a viscosity index of 90W. Remove oil level plug on side of gearbox, fill gearbox until oil runs out the side plug. Refit oil level plug. Check gearbox daily for evidence of leakage. Have your dealer assist you should leakage be found.
- Lubricate the PTO universal joint every eight operating hours. Failure to maintain proper lubrication could result in damage to Universal Joints, gearbox and driveline. To lubricate the shaft itself, lower implement to the ground, disconnect PTO Shaft from tractor and slide the PTO halves out until almost disconnected from each other. Apply a bead of grease completely around male half where it meets the female half. Slide over each other several times repeatedly to distribute grease.
- If the unit is fitted with a roller or rear castor lubricate all grease points every 8 hours.

CUTTER BAR AND BLADE SERVICING

- It will be necessary to gain access to the bottom side of the slasher to change the blades. Disconnect PTO Shaft from the tractor, raise implement and block securely as outlined in “Blocking Method”, before changing the blades.
- Remove nuts and then carefully remove blade bolt. If blade bolt is seized in the cross bar, to prevent gearbox damage, it may be necessary to completely unbolt rotor before driving the old bolt out.
- **If it is necessary to completely remove the rotor it is important that you work from the side of it and not from directly underneath. Also ensure that it is well supported as the cross bars are heavy and could drop suddenly during unbolting, causing severe injury or death.**
- Always replace or sharpen both blades at the same time. Inspect blade bolts for nicks and gouges; replace if any are found. Insert blade bolt through lower part of the blade beam, then through the blade with the hardened bush inserted.
- Finally insert through the top part of the blade beam and secure with a nyloc nut. Blade should swivel on the bolt, if it does not, determine the cause (i.e. maybe nut too tight) and rectify.
- Blade beam rotation is anti-clockwise when looking down on the slasher. Be sure to install blade cutting edge to lead in an anti-clockwise direction.
- When sharpening blades grind each blade the same amount to maintain balance. Replace blades in pairs. Unbalanced blades will cause excessive vibration that can damage gearbox bearings. Vibration may also cause structural cracks to the implement and/or gearbox housing.

SETTING THE CLUTCH

Gearbox protection is provided by a slip clutch with replaceable discs. The slip clutch is designed to slip when excessive torsion loads are encountered. All new clutches supplied with Fieldquip implements have been preset by the following guide.

- Compress springs fully then back off two (2) turns.
- Fine tune so that the clutch slips occasionally.
- On 20 spline models, clutch retaining (clamp) bolts must be tightened to 150 ft/lbs to clamp clutch to shaft - LOOSE BOLTS = STRIPPED SPLINES.

Note: Discs are approximately 3.2mm thick when new. Replace discs after 1.6mm of wear. Minimum disc thickness is 1.6mm.

A new slip clutch, or one that has been in storage for some time, may be seized. Annually, release springs completely and allow clutch to slip to polish pressure plate. To do this you will have to carry out the following operations:

- Make sure tractor is turned off and key is removed.
- Remove PTO Shaft from the tractor.
- Loosen the bolts to remove all tension from the springs.
- Wedge the blade beam so that it cannot rotate.
- Grab PTO Shaft or clutch input shaft and turn to make sure clutch slips.
- If clutch does not slip freely, disassemble and clean the face of the clutch pressure plates and spline base assembly.
- Reassemble clutch.
- Tighten each bolt evenly until the springs are compressed, then back off all nuts two (2) full turns.
- If clutch continues to slip then tighten each bolt half a turn at a time until clutch is no longer slipping.
- If springs are compressed to 24mm, check friction discs for excessive wear. Discs are approximately 3.2mm thick when new. Replace discs after 1.6mm of wear. Minimum disc thickness is 1.6mm. Every individual is operating in a slightly different environment with a range of variables that determine how the clutch must be set for their operation. The size of the tractor, the size of implement and the work being carried out and the terrain are all factors that determine the clutch setting. A quarter or half a turn can make a big difference. It is for this reason that each clutch should be reset for your operating conditions.

THE CLUTCH

Parts suit FQ7790 150 HP CLUTCHES 200 mm (8") 6 Plate Clutch

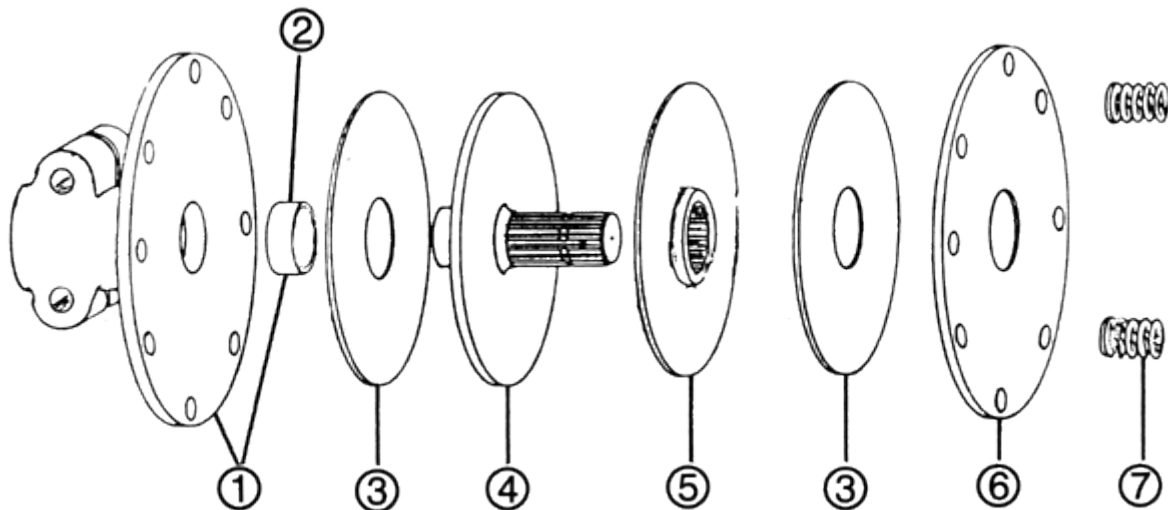

REF	PART No.	DESCRIPTION
1	B4720	1 3/4" x 20 Spline BASE ASSEMBLY (includes bush) Uprated H.T. Casting 5/8" Clamp Bolts
2	B6828	BUSH
3	B3721	FRICITION DISC 165mm (6 1/2") OD x 64mm (2 1/2") ID (6 req)
4	B7791	1 3/4" x 20 spline DRIVE PLATE- Total length = 155mm (6")
5	B7071	INTERMEDIATE PRESSURE PLATE 1 3/4" x 20 spline
6	B4155	OUTER PRESSURE PLATE(3 req)
7	B3723	SPRING (8 req.)

GEARBOX SERVICE

The information in this manual requires special skills and tools. If you are not properly equipped or your mechanics are not properly trained in this type of repair, you may void your warranty or cause more damage leading to a larger repair bill.

- Never place any part of the body underneath the implement or between moveable parts even when engine has been turned off. Hydraulic systems can “creep” (i.e. slowly lower). They may fail or movement of the control levers can cause the implement to drop or rotate unexpectedly causing severe injury or death.
- Follow Operator’s Manual instructions for working on your implement or have servicing carried out by a qualified dealer.
- During routine checks and/or repairs ensure that no one can switch on the tractor or implement accidentally. Keep the key to the tractor in your pocket.
- Keep all persons away from operator control area while performing adjustments, service or maintenance.
- Always wear relatively tight fitted clothing to avoid entanglement in moving parts. Wear heavy duty, rough-soled boots and protective equipment for eyes, hair, hands, hearing and head.

Fill gearbox with high quality gear oil with a viscosity index of 90W. Fill gearbox until oil runs out the side plug on the gearbox. Gearbox Oil should be changed every 1000 hours of use or every two (2) years. Always drain oil into a container and dispose of it properly to protect the environment. Oil level must be checked daily. The composition of oil deteriorates over time and the intense heat that occurs when operating a gearbox reduces the oil level. Low oil levels will result in wear of gearbox components that overtime will result in component failure that could have been prevented.

GEARBOX MAINTENANCE

- During routine checks and/or repairs ensure that no one can switch on the tractor or Implement accidentally. Keep the key to the tractor in your pocket.
- Keep all persons away from operator control area while performing adjustments, service or maintenance.
- Do not carry out any servicing on the gearbox if it has been operating. Gearboxes and the oil inside are very hot during operations and for sometime after you have finished and can cause serious burns. Always wait for gearbox to cool down.

Repair to this gearbox should be limited to replacing bearings, seals and gaskets. Replacing gears, shafts and a housing is not cost effective. It is more economical to purchase a complete gearbox if repairs other than bearings, seals and gaskets are required. It is highly recommended that the customer be given the costs involved in both scenarios.

- Inspect gearbox for leakage and bad bearings. Leakage is a very serious problem and must be corrected immediately. Excessive noise and side to side or endplay in the shafts indicate bearing failure. Leakage can occur at the vertical or horizontal gasket and shaft seals. Leakage from the horizontal gasket or seal can be repaired without removing the gearbox from the slasher.
- Proper seal installation is important. An improperly installed seal will leak. Always ensure the area where the seal outer diameter sits is clean. Always inspect the area of the shaft where the seal sits and remove any burrs or nicks with emery cloth.
- Always lubricate gear shaft and seal lips before assembling. Remove and replace any seals damaged during assembly.
- When assembling gearboxes always clean housing paying specific attention to areas where gaskets will be installed. Wash housing and all components thoroughly. Select a clean area where you can assemble the gearbox. Replace any damaged seals, bearings or gaskets. All parts must be clean and lightly oiled before reassembled.

GEARBOX

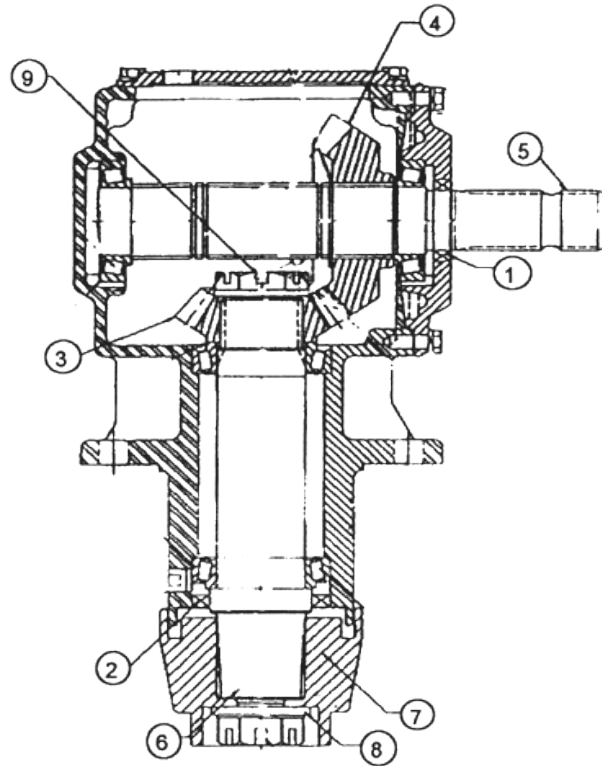

GEARBOX SPARE PARTS		
Ref	Part No.	Description
1	FQ6673	Input Seal
2	FQ9070	Output Seal
3	FQ3257	Output Gear 13 teeth (1 : 1.467 ratio)
	FQ4351	Output Gear 19 teeth (1.188 : 1 ratio)
	FQ9671	Output Gear 17 teeth (1 : 1 ratio)
4	FQ3256	Input Gear - 19 Teeth (1 : 1.467 ratio)
	FQ4350	Input Gear - 16 Teeth (1.188 : 1 ratio)
	FQ9671	Input Gear 17 teeth (1 : 1 ratio)
5	FQ3259	Input Shaft
6	FQ1226	Output Shaft
7	FQ1227	Output Hub
8	FQ1228	Lower Output Nut
9	FQ3258	Top Output Nut

	XHD / X-TREME 70	XHD / X-TREME 80	XHD / X-TREME 90
Complete Gearbox	FQ8667	FQ8668	FQ8668

SPARE PARTS FOR XHD/X-TREME SERIES SLASHER

XHD SERIES SLASHER SPARE PARTS LIST

	XHD 70	XHD 80	XHD 90
Code	Description	Description	Description
1	Main Deck	Main Deck	Main Deck
2	Skid (LH/RH)	Skid (LH/RH)	Skid (LH/RH)
3	Skid Wear Plates	Skid Wear Plates	Skid Wear Plates
4	Gear Box	Gear Box	Gear Box
5	PTO Cover	PTO Cover	PTO Cover
6	A Frame	A Frame	A Frame
7	Chain Back-Stay	Chain Back-Stay	Chain Back-Stay
8	2 Blade Carrier	2 Blade Carrier	2 Blade Carrier
9	Blade	Blade	Blade
10	4 blade Carrier	4 blade Carrier	4 blade Carrier
12	Castle Nut	Castle Nut	Castle Nut
13	Split Pin	Split Pin	Split Pin
14	Top Link Pin	Top Link Pin	Top Link Pin
15	Lynch Pin	Lynch Pin	Lynch Pin
16	Lower Link Pin	Lower Link Pin	Lower Link Pin
17	Bolt-Nut-Washer	Bolt-Nut-Washer	Bolt-Nut-Washer
18	Bolt-Nut-Washer	Bolt-Nut-Washer	Bolt-Nut-Washer
19	Bolt-Nut-Washer	Bolt-Nut-Washer	Bolt-Nut-Washer
20,21,22,23	Bolt-Nut-Washer Pack (2)	Bolt-Nut-Washer Pack (2)	Bolt-Nut-Washer Pack (2)
20	Split Pin	Split Pin	Split Pin
21	Castle Nut	Castle Nut	Castle Nut
22	Clevis Washer	Clevis Washer	Clevis Washer
23	Clevis Washer	Clevis Washer	Clevis Washer
24	Bolt	Bolt	Bolt

X-TREME SERIES SLASHER SPARE PARTS LIST

	X-TREME 70	X-TREME 80	X-TREME 90
Code	Description	Description	Description
1	Main Deck	Main Deck	Main Deck
2	Skid (LH/RH)	Skid (LH/RH)	Skid (LH/RH)
3	Skid Wear Plates	Skid Wear Plates	Skid Wear Plates
4	Gear Box	Gear Box	Gear Box
5	PTO Cover	PTO Cover	PTO Cover
6	A Frame	A Frame	A Frame
7	Chain Back-Stay	Chain Back-Stay	Chain Back-Stay
8	2 Blade Carrier	2 Blade Carrier	2 Blade Carrier
9	Blade	Blade	Blade
10	4 blade Carrier	4 blade Carrier	4 blade Carrier
12	Castle Nut	Castle Nut	Castle Nut
13	Split Pin	Split Pin	Split Pin
14	Top Link Pin	Top Link Pin	Top Link Pin
15	Lynch Pin	Lynch Pin	Lynch Pin
16	Lower Link Pin	Lower Link Pin	Lower Link Pin
17	Bolt-Nut-Washer	Bolt-Nut-Washer	Bolt-Nut-Washer
18	Bolt-Nut-Washer	Bolt-Nut-Washer	Bolt-Nut-Washer
19	Bolt-Nut-Washer	Bolt-Nut-Washer	Bolt-Nut-Washer
20,21,22,23	Bolt-Nut-Washer Pack (2)	Bolt-Nut-Washer Pack (2)	Bolt-Nut-Washer Pack (2)
20	Split Pin	Split Pin	Split Pin
21	Castle Nut	Castle Nut	Castle Nut
22	Clevis Washer	Clevis Washer	Clevis Washer
23	Clevis Washer	Clevis Washer	Clevis Washer
24	Bolt	Bolt	Bolt

TROUBLE SHOOTING

Problem	Possible Causes	Solution
Grass cut is lower in the centre than on the edges.	Height of the slasher lower at the front or rear.	Adjust height and attitude so that the front and rear of the slasher are within 20mm of the same height. See instructions.
Slasher is "Streaking" (i.e. not cutting cleanly.)	Conditions too wet for cutting. Wet grass.	Allow grass to dry before cutting.
	Blades unable to cut the grass that the tractor tyres pressed down.	Reduce ground speed but maintain maximum rpm at the tractor PTO as specified in "Specifications." Lower cutting height.
	Dull Blades.	Sharpen or replace blades.
Material discharged from slasher is uneven and in clumps.	Material being cut is too long and/or has too much volume.	Reduce ground speed but maintain maximum rpm at the tractor PTO as specified in "Specifications" or make two passes. First pass higher than the second and the second at 90° to the first.
	Wet grass.	Allow grass to dry before cutting. Reduce ground speed but maintain maximum rpm at the tractor PTO as specified in "Specifications."
	Rear of slasher too low, trapping material underneath.	Adjust slasher height and attitude (See instructions.)
Slasher will not cut all the time and the clutch smokes when it's not cutting.	Slip clutch is slipping.	Adjust slip clutch according to instructions in the "owner Service" section of this manual

PRE-DELIVERY CHECKLIST

(Dealers Responsibility)

Inspect implement thoroughly after assembly to be certain it is set up properly before delivering it to the customer. The following checklist is a reminder of points to inspect. Check off each item as it is found satisfactory either before or after corrections or services performed.

- Check all bolts and ensure that they are tight.
- Check all cotter pins and linkage pins and ensure they are properly installed and can be secured.
- Check that any “wear points” (i.e. Points, blades, edges, tines) have been properly installed.
- Check PTO series is correct and that the PTO is the correct length.
- All lubrication is completed (refer to lubrication instructions and lubricate implement).
- Ensure that gearbox has correct oil and volume.
- All hydraulic fittings and hoses have been correctly installed.
- Ensure the stability of the tractor has not been compromised.
- All guards, safety features and decals are in place and secure.
- The product number and serial number are recorded FQ____ - _____

Dealer Delivery Information

Dealers please note that, even if the implement is delivered to you fully assembled, an authorised company representative with mechanical knowledge should still carry out the pre-delivery checks to ensure that nothing has come loose in transit. Check gearbox oil level before use, top up if needed, check seals are in good condition and not leaking. Refer to lubrication instructions and lubricate implement. Check that blades have been properly installed. Show customer how to make adjustments. Describe the options available for the implement and explain the purpose and how they work. Explain the importance of lubrication to the customer and point out all the lubrication points on the implement. Point out the safety features, shielding or safety chains. Ensure the stability of the tractor has not been compromised with the implement the customer has purchased. Remember a minimum 20% of tractor and equipment gross weight must be on the tractor's front wheels with implement in the transport position. If you are adding weight to the tractor to attain the 20%, you must not exceed the ROPS max ballasted mass certificate. Weigh the tractor and implement. Do not estimate. Give Operators Manual to the customer and recommend the customer become familiar with all sections, especially the safety and safe operating procedures. Explain to the customer that when transporting the implement on roads or highways, day or night, safety devices should be used to provide adequate warning to operators of other vehicles. Also explain the operator must ensure that the tractor and implement complies with current State and Federal laws and must strictly adhere to all road traffic regulations in force in his/her particular state.

Ensure the customer has signed the WARRANTY REGISTRATION & INSTALLATION FORM and a copy has been returned to Fieldquip Australia, PO Box 333 Oakey QLD 4001

WARRANTY

All Fieldquip machinery is covered by a comprehensive warranty against faulty materials and workmanship provided that (i) The machine is operated in normal use, (ii) The machine is correctly serviced and maintained, (iii) The machine is worked within its stated capacity (i.e. Horsepower limit and PTO Speed), (iv) The machine is not subjected to any modifications or damage from improper use, (v) Fieldquip is in receipt of duly signed pre-delivery and installation certificate and warranty documentation.

The term of warranty shall be 12 months from date of installation except machines sold into the Hire Industry; these shall be void of warranty.

The following items are not covered by Fieldquip warranty; (i) Power Take-off shafts and clutches, (ii) Blades, tynes, knives, tyres, belts etc. (iii) Freight costs, (iv) Loss of income from the machine due to a warranty fault, (v) Use of non genuine parts.

The manufacturer's obligation under this warranty is limited to correcting without charge at its factory or by one of its authorised Dealers, with the manufacturer's approval, any parts thereof, within 12 months from date of purchase by the original user, and which upon examination shall disclose to the manufacturer's satisfaction to have been originally defective.

Correction of such defects by repair to, or supplying of replacements of defective parts, shall constitute fulfilment of all obligations to the original user: Manufacturer shall not be liable for loss, damage, or expense directly or indirectly from the use of its product or from any other cause. Defective parts must be returned freight paid each way by the purchaser to the manufacturer.

This warranty shall apply to any parts which must be replaced because of normal wear, or which have not been repaired or altered outside of the manufacturer's factory unless authorised by the manufacturer. This warranty should not be construed as a free service period during the warranty period.

No person, agent or dealer is authorised to give any warranties on behalf of the manufacturer or to assume for the manufacturer any other liability in connection with any of its product unless made in writing from the manufacturer.

All claims will be null and void if any warranty work is commenced without prior approval from Fieldquip.

WARRANTY PROCEDURE

- Contact Dealer who will contact Fieldquip
- Photos of repair required emailed to warranty@fieldquip.com with description of problem
- Claim will be assessed by warranty department and if repair is approved a warranty claim number and form will be issued.
- This process is designed to take no longer than 24hrs from receiving email requesting warranty.
- Warranty claim form to be returned to Fieldquip prior to reimbursement.
- Under no circumstances will travel, freight charges be recognised under warranty this is the responsibility of the owner.
- Please note that not all items are covered under warranty, refer to warranty card. If unsure please contact warranty claim department on (07) 4691 1500.
- Under no circumstance should work be commenced without a warranty claim form number and approval.
- Fieldquip will not recognise any work carried out without a warranty claim number.

PRODUCT CHECKLIST - Delivery

- The customer has been given the Operator's Manual, Task Hazard Analysis and Farm Machinery Safe Work Practices.
- The customer has been advised to read the complete Operator's Manual and understand its contents, especially the safety and operation procedures, prior to operation of the machine.
- All safety information has been explained, and decals, guards and serial number identified.
- The customer has been advised about transporting the implement on roads or highways.
- The maintenance of the implement has been explained.
- The starting and operating procedures have been explained.

I acknowledge that all of the delivery items listed above have been reviewed on delivery.

Dealers Name: _____

Address: _____

Customers

Name: _____

Address: _____

Customer's Signature: _____ Date: _____

Dealer's Signature: _____ Date: _____

Please Note: A signed complete copy of this form must be returned to us, with the "Warranty Registration & Installation Form" for legal & warranty purposes.

Ensure the customer has signed the WARRANTY REGISTRATION & INSTALLATION FORM and a copy has been returned to Fieldquip Australia Pty Ltd, PO Box 333 Oakey, Queensland 4401

DELIVERY, WARRANTY AND SAFETY ACKNOWLEDGEMENT

To be completed by the dealer and purchaser at the time of delivery and returned to Fieldquip

Dealer Name and Address:

.....
.....
.....

On behalf of the above dealership I hereby state:

1. This is a new machine and has been thoroughly checked by our personnel prior to delivery and is in safe working condition.
2. I have fully explained the warranty including the owner's responsibility to pay for travelling costs and expendable items.
3. I have supplied the owner with an operator's manual and explained the service and safety aspects of the machines operation and the existence of the relevant safety standards.
4. I have shown the owner the service point of the machine and explained the importance of regular service.
5. I have delivered the operators manual and warranty card.
6. I have reviewed the contents of these books including the relevant sections on safety with the new owner.
7. I have demonstrated the machines safety features and explained the approved work practices.
8. I have discussed the approved codes of practice which apply to this type of machine.
9. I will arrange to return this form to Fieldquip for registration within 14 days of sale along with the warranty card.

Name: (Block Letters) Position Title:

Signature: Date:

Owners Name and Address:

.....
.....
.....

I hereby acknowledge:

1. I have received and accepted delivery of the machine listed above.
2. The machine has been delivered to me with all systems functioning and running to my satisfaction.
3. I have been instructed and understand the application, limitations and capabilities that the machine has been designed for.
4. I understand and accept the Fieldquip warranty and understand I am responsible to pay for travelling costs and expendable items.
5. I have received an operator manual and warranty card and have reviewed their content regarding the correct operation of the machine.
6. I will be expecting confirmation of this warranty registration from Fieldquip.
7. The dealer has supplied an owner's manual with the machine and reviewed the sections on safety with me making any explanations that may be required.
8. I am particularly aware of the importance of not operating the machine outside the safety guidelines.
9. I understand the principles of safe operation of this machine and accept responsibility to ensure that any persons who operate this machine are properly instructed in these matters.
10. In the event that the regulatory authorities or Fieldquip should require modifications or new service procedures to be made or adopted we indemnify Fieldquip and the dealer from any liability or cost which may be involved.
11. In the event that ownership of this machine should pass from me, I undertake to pass responsibility for the above matters on to the new owner and I will advise Fieldquip of the change of ownership.

Name: (Block Letters) Position Title:

.....

Signature: Date: